



Roco

40360

Universal-Beleuchtungssatz Universal lighting set Jeu d'éclairage universel Illuminazione universale Universele Verlichtingsset



ACHTUNG !

Packungsinhalt: 16 V/22 mA-Lampensatz (Ersatzteil Nr. 40321, enthält 5 Lampen) für Digitalbetrieb!
Im Analogbetrieb haben diese 16 V-Lampen eine sehr geringe Leuchtkraft. Für den **Analogbetrieb** empfehlen wir, den **12 V-Lampensatz (Art.-Nr. 40322, enthält 5 Lampen)** zu verwenden, den Sie bei Ihrem Fachhändler oder über den ROCO-Ersatzteilservice erhalten. Die Adresse Ihrer jeweiligen Landesvertretung finden Sie im ROCO-Katalog.

WARNUNG! Die Verwendung von 12 V-Lampen im Digitalbetrieb kann zu irreparablen Schmelzschäden am Fahrzeuggehäuse führen!



NOTE !

Package contents: 16 V/22 mA bulb set (replacement parts no. 40321, contents 5 bulbs) for digital use!
Under **conventional operation** the 16 V bulbs are very dim. We recommend using the **12 V bulb exchange set (art.no. 40322, content 5 bulbs) for conventional use**. Exchange sets are available at your hobby shop, or from the ROCO-Accessories Service. Please see the ROCO catalogue for the address of your local distributor.

WARNING! Do not use 12 V bulbs under digital operation, this can cause irreparable damage (melting) to the casing!



ATTENTION !

Contenu du sachet: Jeu d'ampoules d'éclairage (Pièces de Rechange réf. 40321, 5 ampoules) pour réseaux à commande numérique!

En exploitation à commande classique (dite: analogique) ces ampoules 16 V/22 mA donnent une lumière trop faible. Nous vous conseillons donc, pour ce mode de commande, de faire appel au jeu d'ampoules d'éclairage en 12 V (réf. 40322, 5 ampoules). Ce jeu d'ampoules se trouve chez votre détaillant habituel ou, contre remboursement des frais postaux, en direct chez le SAV de votre importateur national (voir adresse dans le catalogue général ROCO).



IMPORTANT! L'utilisation d'ampoules d'éclairage 12 V sur un réseau à commande numérique surchauffe les ampoules et peut donc causer des destructions irréparables aux toits et caisses des véhicules munis d'éclairage intérieur, ceux-ci risquent de fondre sous l'effet de la chaleur!



ATTENZIONE !

Contenuto della confezione: sistema di illuminazione con lampadine a 16 V/22 mA (Art.-Nr. 40321, 5 lampadine) per impianti con azionamento digitale!

Su impianti con azionamento analogico la lampadine a 16 V hanno una bassa intensità luminosa. Per impianti tradizionali ad **azionamento analogico** consigliamo di utilizzare pertanto il sistema di illuminazione con lampadine a 12 V (Art.-Nr. 40322, 5 lampadine), che troverete presso il Vostro rivenditore specializzato o presso il Servizio pezzi di ricambio ROCO. Trovate l'indirizzo del Vostro distributore nazionale sul catalogo ROCO.

AVVERTENZA! L'impiego di lampadine a 12 V con l'azionamento digitale provoca danni irreparabili alla cassa del veicolo per surriscaldamento!



LET OP !

40320: Bevat lampjes 16 V/22 mA, voor een digitale baan. Deze geven te weinig licht op een analoge baan.

40321: Set met 5 lampjes 16 V.

40322: Set 5 lampjes 12 V voor een analoge baan.

WAARSCHUWING! De 12 V lampjes worden op een digitale baan gloeiend heet en kunnen daardoor het model doen smelten en de kunststof behuizing ernstig beschadigen!

Fig. 1

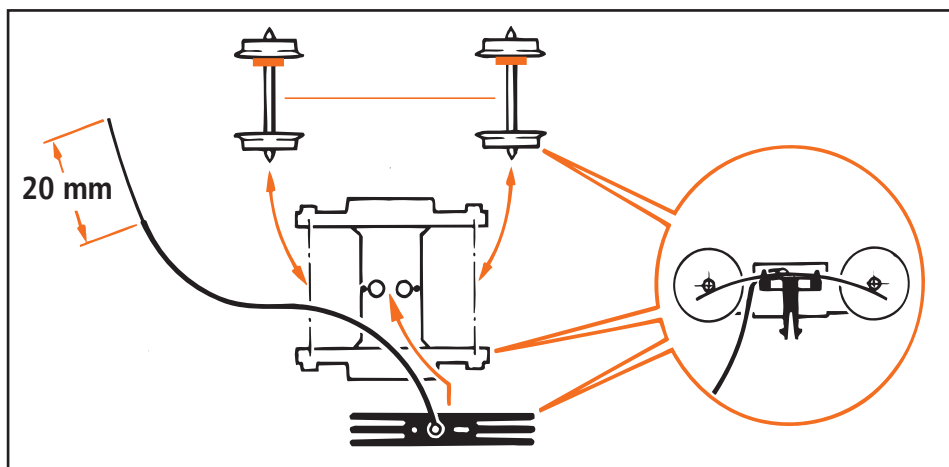



Roco

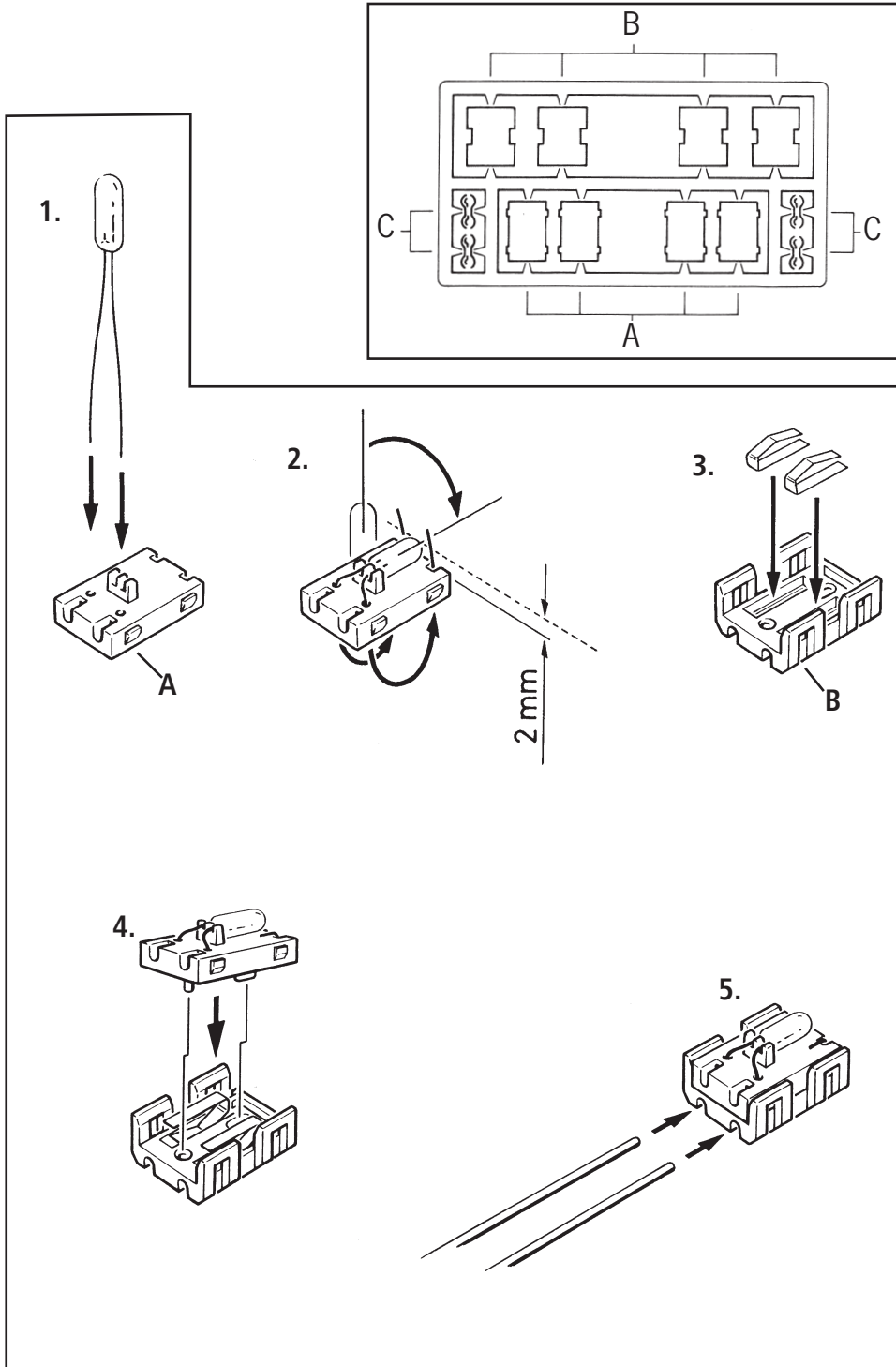

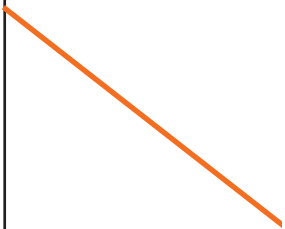
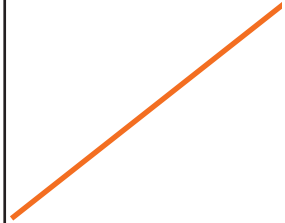
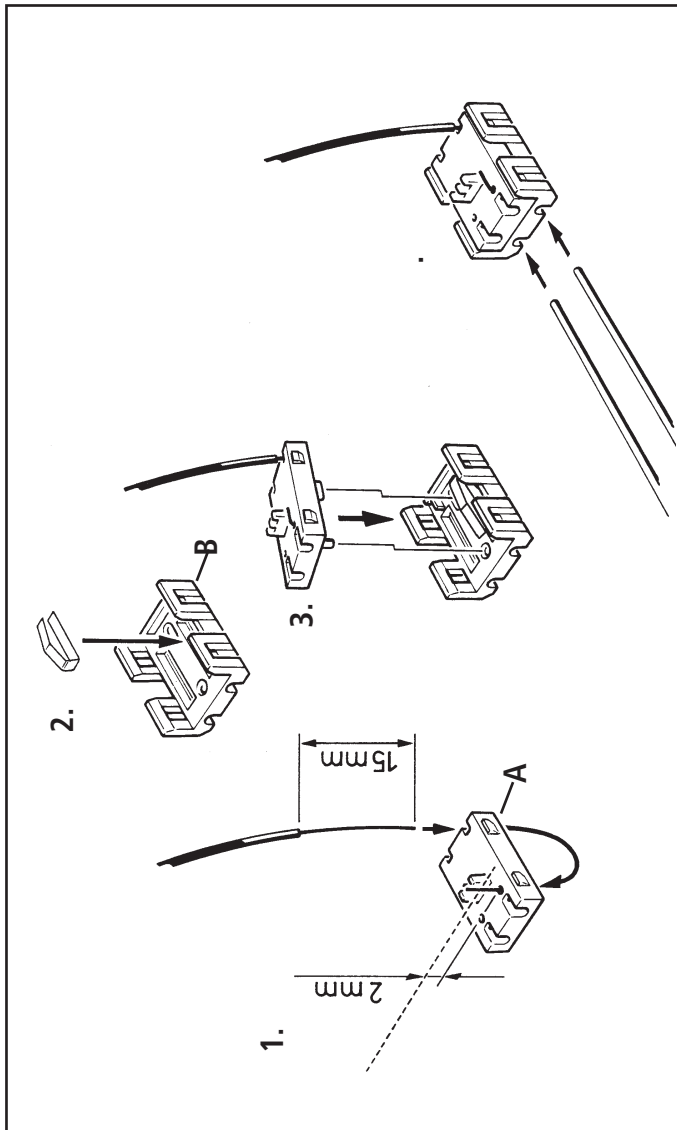

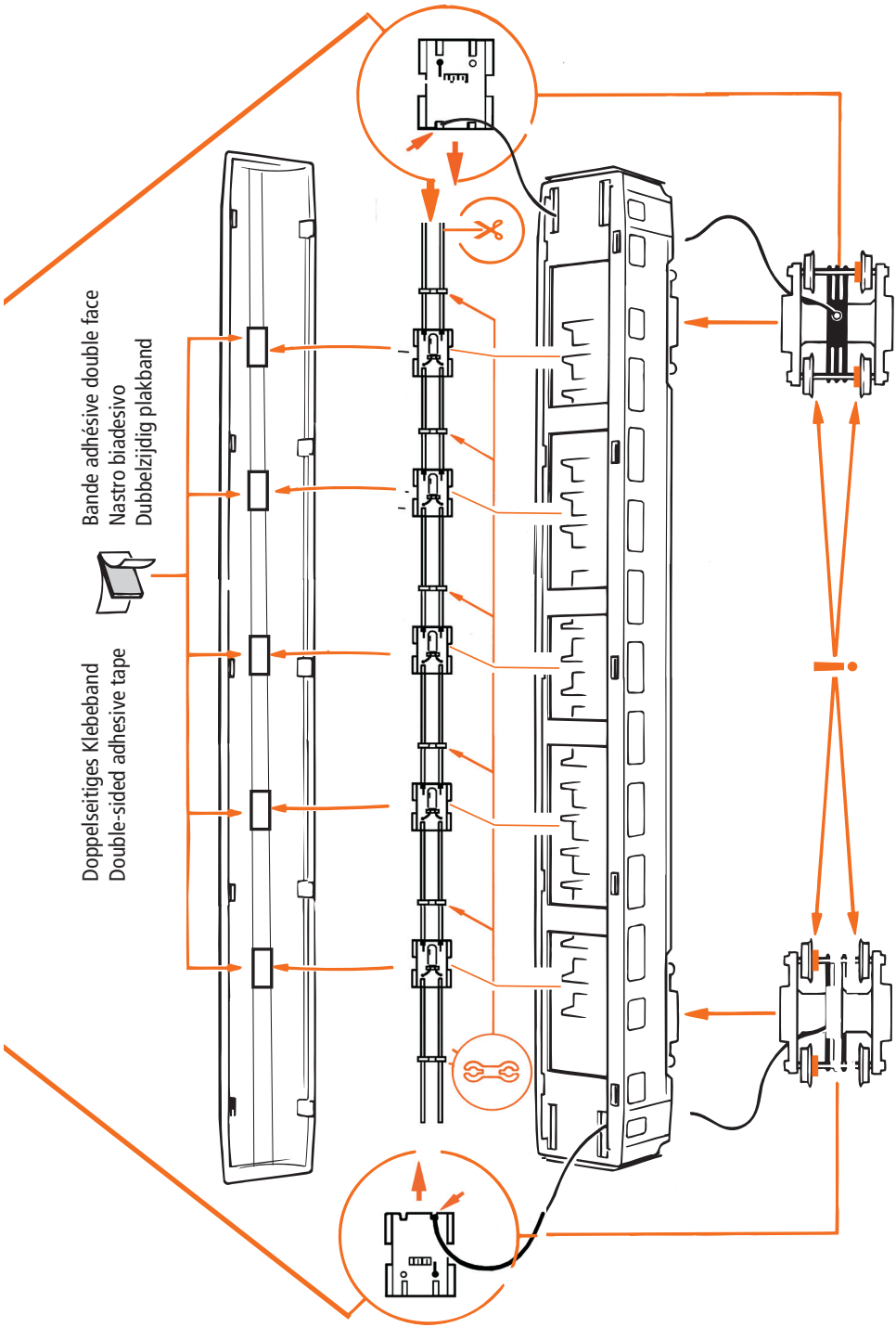

Diagonaleinbau der Drehgestelle bei einseitig isolierten Radsätzen!
 Diagonal connection for wheel sets with only one side insulated!
 Montage en quinconce avec essieux à une roue isolée !
 Collegamento diagonale con assali isolati su un lato!
 Diagonaal verbinden aan eenzijdig geïsoleerde wielen!





Änderungen von Konstruktion und Ausführung vorbehalten! • We reserve the right to change the construction and design! • Nous nous réservons le droit de modifier la construction et le dessin! • Ci riserviamo il diritto di variare la costruzione e il design! • Verandering van model en constructie voorbehouden.

Bitte diese Beschreibung zum späteren Gebrauch aufbewahren! • Please retain these instructions for further reference! • Pièze d' bien vouloir conserver ce mode d'emploi en vue d'une future utilisation! • Conservate queste istruzioni per un futuro utilizzo! • Deze handling altijd bewaren.



Roco

Modelleisenbahn GmbH

Plainbachstraße 4

A - 5101 Bergheim

Tel.: +43 (0)5 7626



8040360920

VI / 2010

